

REVISION		RECORD	
REV.	CONTENT	MOD.	DATE
0	初版发行		

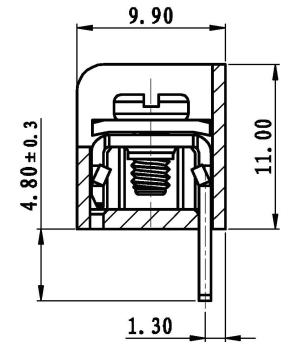
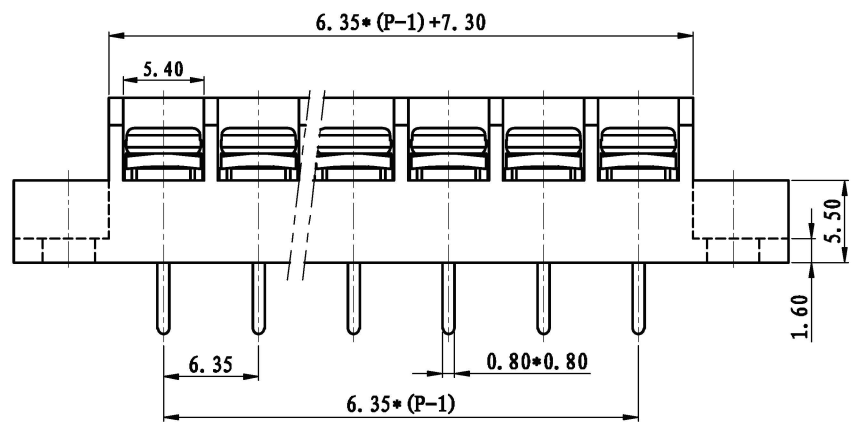
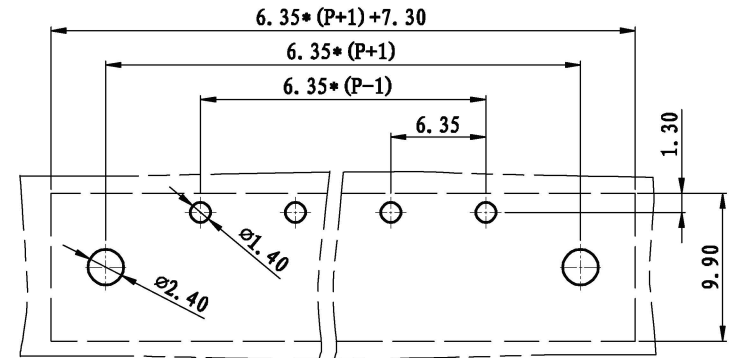
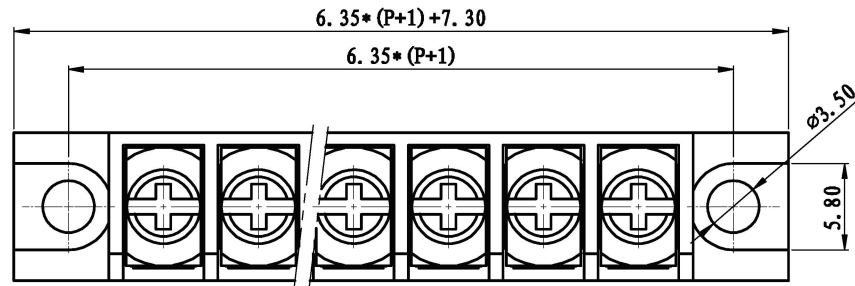

NOTES:

Pitch : 6.35mm  
Rated Voltage : 300V  
Rated Current : 15A  
Withstand Voltage : AC2500V for 1 minute  
Insulation Resistance : 500MΩ / DC500V  
Using Temperature Range : -40℃ ~ +130℃  
Wire range : 22~14 AWG  
Screw Torque Value : 0.4Nm

技术要求:  
间距: 6.35mm  
额定电压: 300V  
额定电流: 15A  
耐电压值: AC2500V/min  
绝缘阻抗: 500MΩ/DC500V  
使用条件: -40℃~+130℃  
适用线规: 22~14 AWG  
螺丝扭矩: 0.4Nm

	pitch dimension			Nominal dimension					— /
	over 0 to 6	over 6 to 10	over 10 to 24	over 0 to 30	over 30 to 60	over 60 to 100	over 100 to 150		
variable range	0 to 6	6 to 10	10 to 24	0 to 30	30 to 60	60 to 100	100 to 150	□	
Tolerance	±0.1	±0.15	±0.25	±0.2	±0.3	±0.5	±0.7	±1.0	○

3	M2.5*5-5.2*5.2	SPPFA2550A1V	P	碳钢	三价铬钝化彩锌
2	LW3-6.35-焊脚	5016B0001AV	P	黄铜	镀雾锡
1	LW3M-6.35-本体	5016M0YXXAV	1	PBT	
NO.	NAME OF PART	NO. OF PART	Q'TY	MATERIAL	NOTES
DES.	ARKINE	DATE	11-06-20	UNITS	MM
CHK.		DATE		SIZE	A4
APP.		DATE		SCALE	1:1
				DWG NO.	SP-2-5016006
				TITLE	LW3MB-6.35-XP-1Y-00A
					LW3MB-6.35-成品

上海有乐电气有限公司  
Shanghai YouLe Electric C O., LTD