

REVISION RECORD			
REV.	CONTENT	MOD.	DATE
△	初版发行		

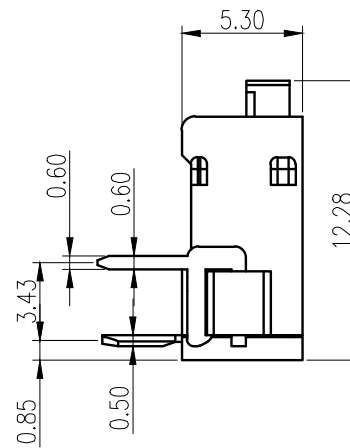
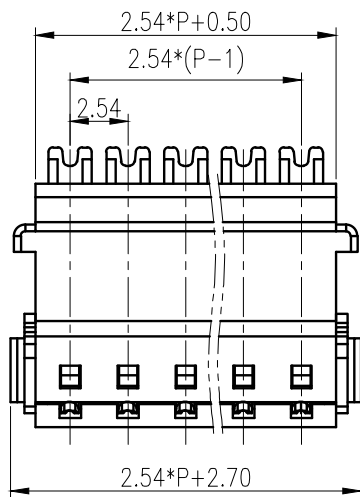
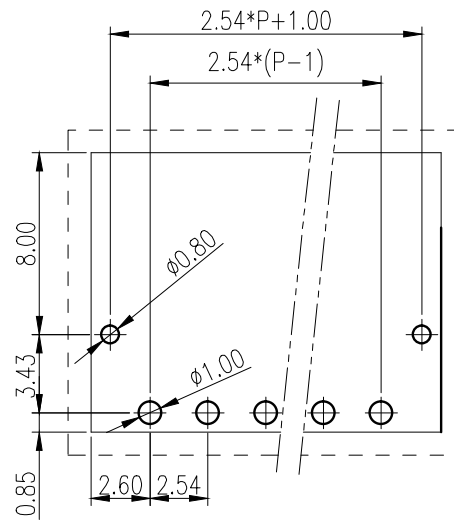
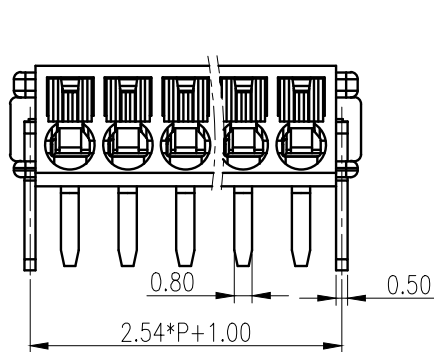

技术要求:  
 间距: 2.54mm  
 额定电流: 6 A  
 额定电压: 160 V  
 耐电压值: AC 2000V/min  
 位数: 2~24

连接方式: 直插式弹簧连接  
 可连接导线横截面 AWG / kcmil 26~20  
 硬导线横截面 0.14 mm<sup>2</sup>~1.0 mm<sup>2</sup>  
 柔性导线横截面 0.14 mm<sup>2</sup>~1.0 mm<sup>2</sup>  
 带不含绝缘套管的冷压头 0.25 mm<sup>2</sup>~0.34 mm<sup>2</sup>  
 带套管, 带塑料绝缘套管 0.14 mm<sup>2</sup>~0.25 mm<sup>2</sup>  
 剥线长度: 7 mm  
 使用条件: -40℃~+105℃

拔出测试  
 导线横截面 / 导线类型 / 拉力  
 0.14 mm<sup>2</sup> / 刚性 / > 10 N  
 0.14 mm<sup>2</sup> / 柔性 / > 10 N  
 0.5 mm<sup>2</sup> / 刚性 / > 20 N  
 0.5 mm<sup>2</sup> / 柔性 / > 20 N

6	耳朵固定针R/1	1169B0004AV	2	不锈钢	
5	LC8-2.54弹片	1169B0002AV	P	不锈钢	
4	LS341-2.54-R针	1171B0002AV	1	磷青铜	镀亮锡
3	LC8按钮	1169D0Y01AV	P	PA66	
2	LS341-2.54盖板	1171A0YXXAV	1	PA66	
1	LC8M-2.54主体	1169M0YXXAV	1	PA66	
NO.	NAME OF PART	NO. OF PART	Q'TY	MATERIAL	NOTES
DES.	ZD	DATE	21/1/22	UNITS	mm
CHK.		DATE		SIZE	A4
APP.		DATE		SCALE	1:1
				DWG NO.	SP-2-1171001
				TITLE	LS341R-2.54-XXP-1Y-00A
					LS341R-2.54-成品

	pitch dimension			Nominal dimension					— ◇ ○
	over 0	over 6	over 10	over 0	over 30	over 60	over 100	over 150	
variable range	to 6	to 10	to 24	to 30	to 60	to 100	to 150		
Tolerance	±0.1	±0.15	±0.25	±0.2	±0.3	±0.5	±0.7	±1.0	0.05/10



上海有乐电气有限公司  
 Shanghai YouLe Electric CO.,LTD

TITLE

LS341R-2.54-XXP-1Y-00A  
 LS341R-2.54-成品