

REVISION RECORD			
REV.	CONTENT	MOD.	DATE
△	新发行		

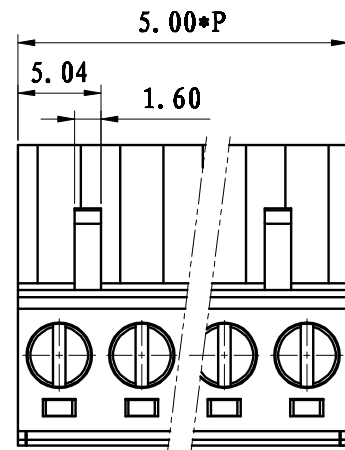

**NOTES:**  
 Pitch : 5.0mm  
 Rated Voltage : 300V  
 Rated Current : 15A  
 Withstand Voltage :  
 AC2500V for 1 minute  
 Insulation Resistance :  
 500MΩ / DC500V  
 Using Temperature Range :  
 -40℃ ~ +105℃  
 Wire range : 28~12 AWG  
 Screw Torque Value : 0.5Nm

**技术要求:**  
 间距: 5.0mm  
 额定电压: 300V  
 额定电流: 15A  
 耐电压值: AC2500V/1min  
 绝缘阻抗: 500MΩ/DC500V  
 使用条件: -40℃ ~ +105℃  
 适用线规: 28~12AWG  
 螺丝扭矩: 0.5Nm

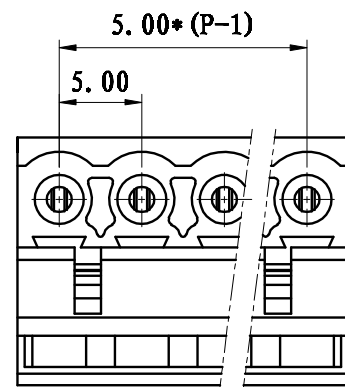
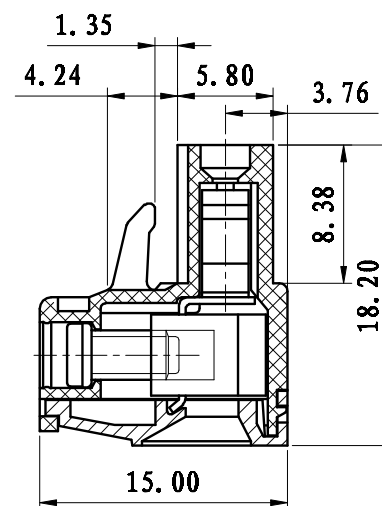

	pitch dimension			Nominal dimension					— /
	over 0	over 6	over 10	over 0	over 30	over 60	over 100	over 150	
variable range	to 6	to 10	to 24	to 30	to 60	to 100	to 150		∩
Tolerance	±0.1	±0.15	±0.25	±0.2	±0.3	±0.5	±0.7	±1.0	0.05/10

5	LC1-5.08-夹子	1001B0001AV	P	磷青铜	镀镍
4	LC1-5.08-螺丝	SPOYA305301Y	P	碳钢	三价铬钝化彩锌
3	LC1-5.08-铜方块	F1A0BLC5083V	P	黄铜	镀镍
2	LC1-5.0-盖板	1040C0YXXAV	1	PA66	
1	LC1-5.0-主体	1040A0YXXAV	1	PA66	
NO.	NAME OF PART	NO. OF PART	QTY	MATERIAL	NOTES
DES.	XLM	DATE	2012/2/27	UNITS	mm
CHK.		DATE		SIZE	A4
APP.		DATE		SCALE	1:1
				DWG NO.	SP-2-1040001
				REV.	V0
				TITLE	LC1-5.0-XXP-1Y-00A
					LC1-5.0-成品

上海有乐电气有限公司  
 Shanghai YouLe Electric CO.,LTD

REVISION RECORD			
REV.	CONTENT	MOD.	DATE
△	初版发行		

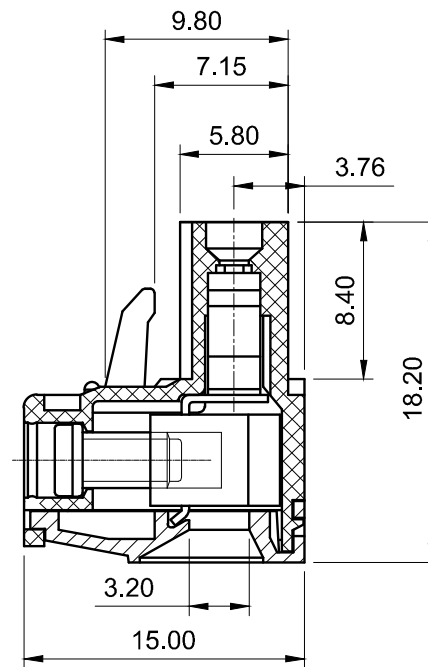
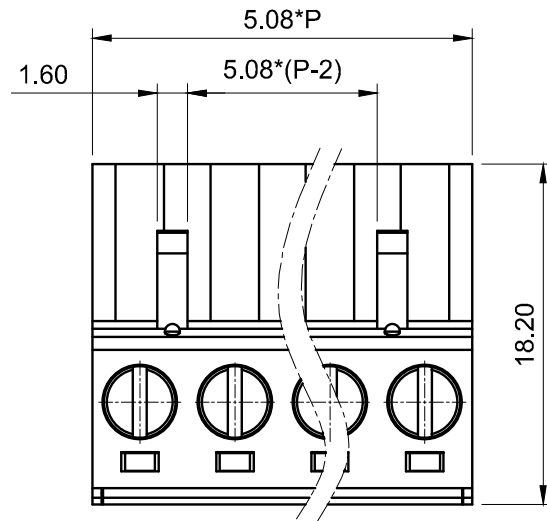
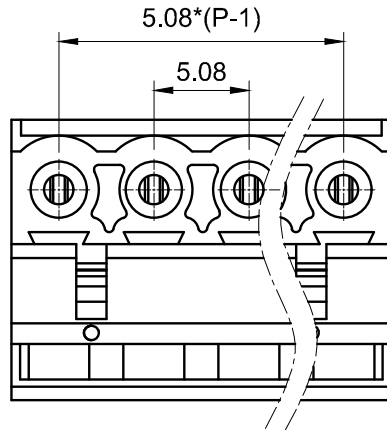

### NOTES:

1. Voltage Rating: 300V, Current Rating: 15A
2. PITCH: 5.08mm
3. Insulation Withstands Voltage: AC2500V/min
4. Insulation Resistance: 500MΩ or more at DC500V
5. Using Temperature Range: -40°C ~ +105°C
6. Suitable Electric Wire: 28-12AWG
7. Screw Torque Value: 0.5 N.m

### 技术要求:

1. 额定电压: 300V, 额定电流: 15A
2. 间距: 5.08mm
3. 耐电压值: AC2500V/min
4. 绝缘阻抗: 500MΩ
5. 使用条件: -40°C ~ +105°C
6. 适用线规: 28-12AWG
7. 螺丝扭力: 0.5 N.m

	pitch dimension			Nominal dimension					—
	over 0	over 6	over 10	over 0	over 30	over 60	over 100	over 150	
variable range	to 6	to 10	to 24	to 30	to 60	to 100	to 150		□
Tolerance	±0.1	±0.15	±0.25	±0.2	±0.3	±0.5	±0.7	±1.0	○

5.	LC1-5.08-夹子	1001B0001AV	P	磷青铜	镀镍
4.	LC1-5.08-铜方块	F1A0BLC5083V	P	黄铜	镀镍
3.	LC1-5.08-螺丝	SPOYA305302V	P	碳钢	三价铬钝化彩锌
2.	LC1-5.08-盖子	1001C0YXXAV	1	PA66	
1.	LC1-5.08-主体	1001A0YXXAV	1	PA66	
NO.	NAME OF PART	NO. OF PART	Q' TY	MATERIAL	NOTES
DES.	WL	DATE	18-05-09	UNITS	MM
CHK.		DATE		SIZE	A4
APP.		DATE		SCALE	1:1
				DWG NO.	SP-1-10010A01
				REV:	V0
				TITLE	LC1-5.08-XXP-1Y-00A
					LC1-5.08-成品



上海有乐电气有限公司  
Shanghai YouLe Electric CO., LTD

TITLE LC1-5.08-XXP-1Y-00A  
LC1-5.08-成品