

REVISION RECORD

REV.	CONTENT	MOD.	DATE
△	初版发行		

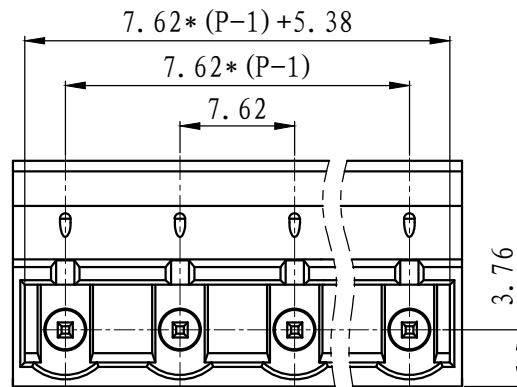
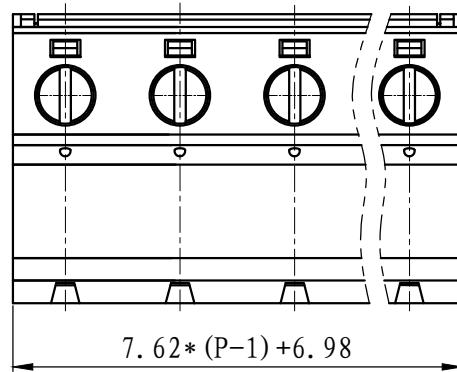

NOTES:
 Pitch : 7.62mm
 Rated Voltage : 400V
 Rated Current : 20A
 Withstand Voltage : AC2500V for 1 minute
 Insulation Resistance : 500MΩ / DC500V
 Using Temperature Range : -40℃ ~ +105℃
 Wire range : 24~12 AWG
 Screw Torque Value : 0.8 N.m

技术要求:
 间距: 7.62mm
 额定电压: 400V
 额定电流: 12A
 耐电压值: AC2500V/min
 绝缘阻抗: 500MΩ/DC500V
 使用条件: -40℃~+105℃
 适用线规: 24~12 AWG
 螺丝扭矩: 0.8 N.m

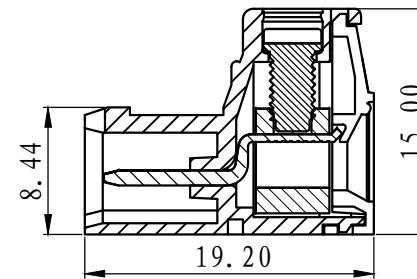

	pitch dimension			Nominal dimension					— ▭ ○
	over 0 to 6	over 6 to 10	over 10 to 24	over 0 to 30	over 30 to 60	over 60 to 100	over 100 to 150	over 150	
variable range	0 to 6	6 to 10	10 to 24	0 to 30	30 to 60	60 to 100	100 to 150	150	
Tolerance	±0.1	±0.15	±0.25	±0.2	±0.3	±0.5	±0.7	±1.0	0.05/10

5.	LC10-5.08-焊脚	1011B00010V	P	紫铜	镀雾锡
4.	LC1-5.08-螺丝	SPOYA305301V	P	碳钢	三价铬钝化彩锌
3.	LC1-5.08-铜方块	F1A0BLC5083V	P	黄铜	镀镍
2.	LC1-7.62-盖板	1007COYXXAV	1	PA66-V0	
1.	LC10-7.62-本体	1132A0YXXAV	1	PA66-V0	
NO.	NAME OF PART	NO. OF PART	Q'TY	MATERIAL	NOTES
DES.	LDD	DATE	2016/02/24	UNITS	MM
CHK.		DATE		SIZE	A4
APP.		DATE		SCALE	1:1
				DWG NO.	SP-2-1132001
				REV:	V0
上海有乐电气有限公司 Shanghai YouLe Electric Co., LTD				TITLE	LC10-7.62-XXP-1Y-00A LC10-7.62-成品