

| REVISION RECORD | | | |
|-----------------|---------|------|------|
| REV. | CONTENT | MOD. | DATE |
| △ | 初版发行 | | |

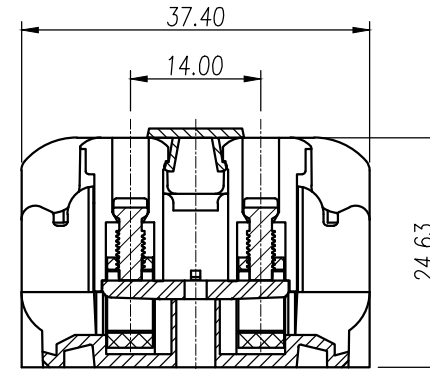
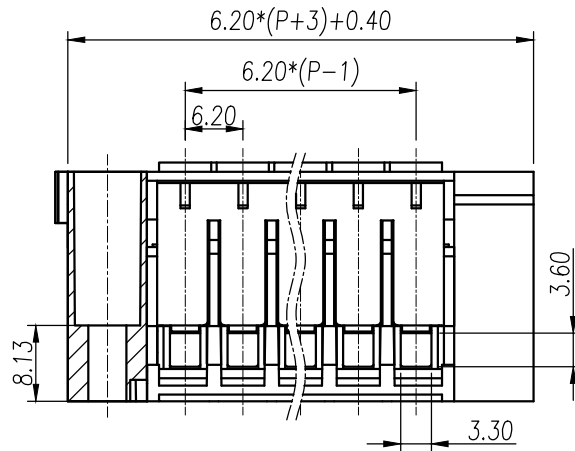
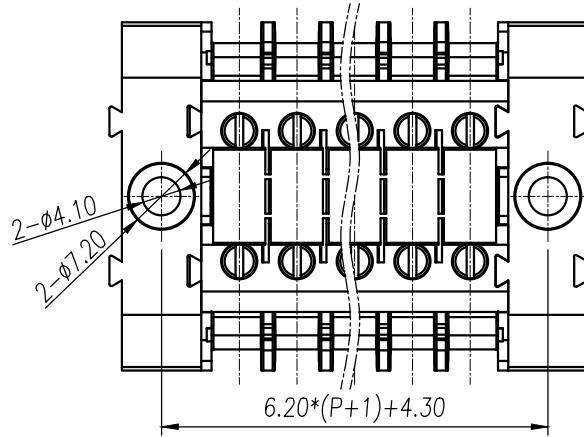

NOTES:

1. Voltage Rating: 800V, Current Rating: 41A
2. PITCH: 6.20mm
3. Insulation Withstands Voltage: AC3500V/min
4. Insulation Resistance: 500MΩ or more at DC1000V
5. Using Temperature Range: -40° C+105° C
6. Suitable Electric Wire: 0.2-4.0mm²
7. Screw Torque Value: 0.5 N.m

技术要求:

1. 额定电压: 800V, 额定电流: 41A
2. 间距: 6.20mm
3. 耐压值: AC 3500V/min
4. 绝缘阻抗500兆欧
5. 使用条件: -40° - +105°
6. 刚柔性导线: 0.2-4.0mm²
7. 螺丝扭力: 0.5 N.m

| | pitch dimension | | | Nominal dimension | | | | | — / |
|----------------|-----------------|--------|---------|-------------------|---------|---------|----------|----------|---------|
| | over 0 | over 6 | over 10 | over 0 | over 30 | over 60 | over 100 | over 150 | |
| variable range | to 6 | to 10 | to 24 | to 30 | to 60 | to 100 | to 150 | | □ ○ |
| Tolerance | ±0.1 | ±0.15 | ±0.25 | ±0.2 | ±0.3 | ±0.5 | ±0.7 | ±1.0 | 0.05/10 |

| | | | | | |
|--|--------------|--------------|------------|----------|---------------------|
| 7 | LD1-2.5M | 6LD11400253V | 2 | PA66 | |
| 6 | ZB6标记条 | ZB6标记条 | P/10 | | |
| 5 | UK5N-导电件 | 6UK5B00001AV | P | 黄铜 | 镀镍 |
| 4 | UK5N-铜方块 | F000000140V | 2P | 黄铜 | 镀镍 |
| 3 | UK2.5B-螺丝 | SSM0300070V | 2P | 合金铜 | 镀镍 |
| 2 | LUX-盖板 | 6LUK0Y0XX3V | 1 | PA66 | |
| 1 | LUX-主体 | 6LUKE0Y0XX3V | 1 | PA66 | |
| NO. | NAME OF PART | NO. OF PART | Q'TY | MATERIAL | NOTES |
| DES. | ZD | DATE | 2020/04/25 | UNITS | MM |
| CHK. | | DATE | | SIZE | A4 |
| APP. | | DATE | | SCALE | 1:1 |
| | | | | DWG NO. | SP-1-LUK1400 |
| | | | | REV: | V0 |
| 上海有乐电气有限公司 Shanghai YouLe Electric Co., LTD | | | | TITLE | LUKM1-2.5/XX-YY-01B |
| | | | | | LUKM1-2.5成品 |