

REVISION RECORD			
REV.	CONTENT	MOD.	DATE
△			

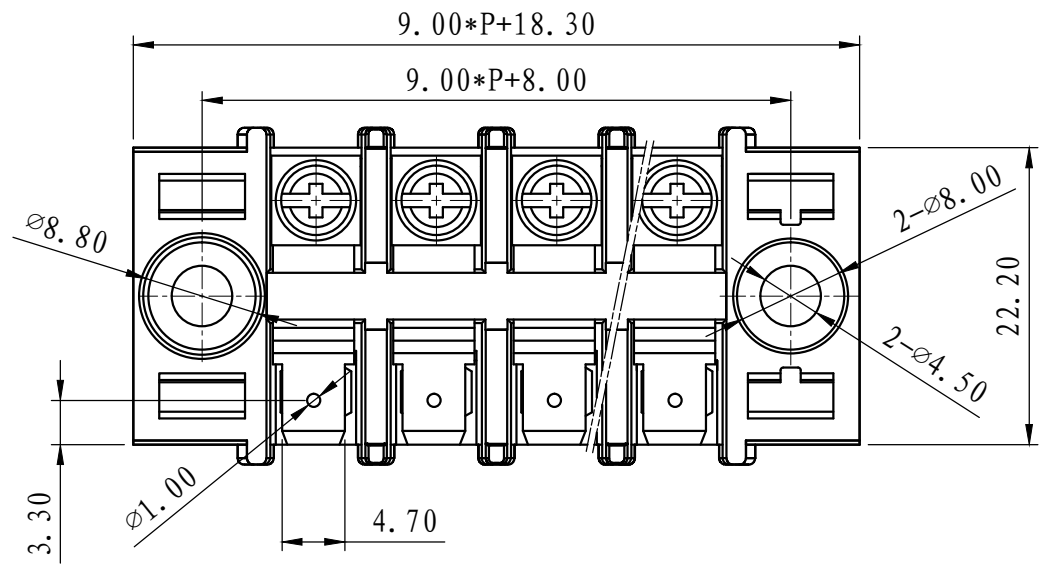

NOTES:
 Pitch : 9.0mm
 Rated Voltage : 600V
 Rated Current : 15A
 Withstand Voltage :
 AC3000V for 1 minute
 Insulation Resistance :
 1000MΩ / DC1000V
 Using Temperature Range :
 -40℃ ~ +105℃
 Suitable Electric Wire : 22-16 AWG
 Screw Torque Value : M3/0.5Nm
 Adaptable terminals : FDD1-187(5)

技术要求:
 间距: 9.0mm
 额定电压: 600V
 额定电流: 15A
 耐受电压值: AC3000V/min
 绝缘阻抗: 1000MΩ/DC1000V
 使用条件: -40℃~+105℃
 适用线规: 22-16 AWG
 螺丝扭矩: M3/0.5Nm
 可适配端头: FDD1-187(5)

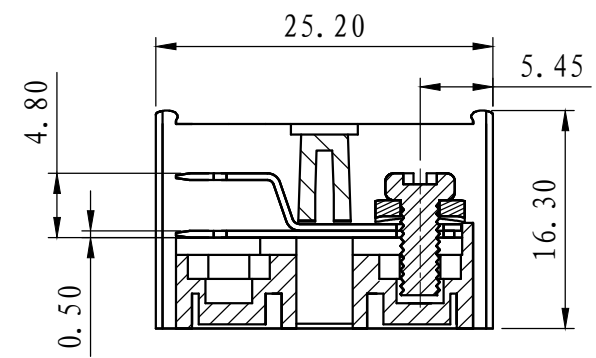
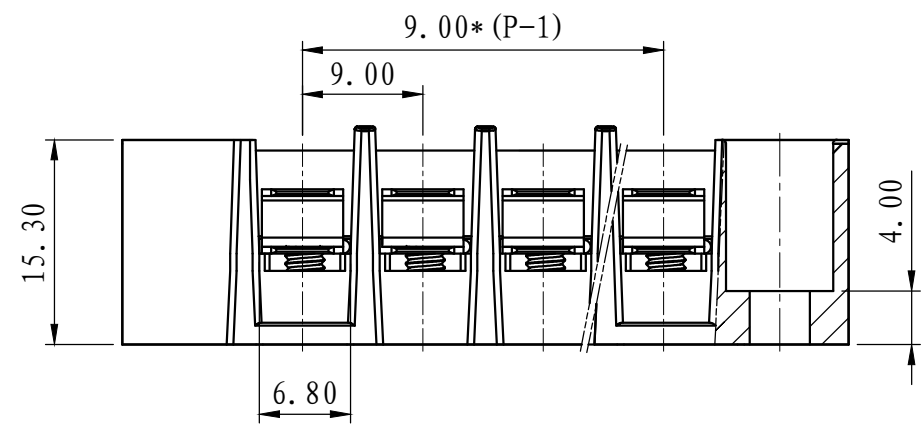

	pitch dimension			Nominal dimension					—
	over 0	over 6	over 10	over 0	over 30	over 60	over 100	over 150	
variable range	to 6	to 10	to 24	to 30	to 60	to 100	to 150		◇
									○
Tolerance	±0.1	±0.15	±0.25	±0.2	±0.3	±0.5	±0.7	±1.0	0.05/10

4	M3外六角螺母	SM00A000003V	P	铁	三价铬钝化彩锌
3	M3*8-6.5*6.5	SPPFA307031V	P	碳钢	镀蓝白锌
2	JX0-15A-导电件	6JX0BDD150AV	P	黄铜	镀镍
1	TB1-15XX-A本体	6TB1E0Y1XX0V	1	PC	
NO.	NAME OF PART	NO. OF PART	Q'TY	MATERIAL	NOTES
DES.	LDD	DATE	2012/07/03	UNITS	mm
CHK.		DATE		SIZE	A4
APP.		DATE		SCALE	
				DWG NO.	SP-2-6TB1E15
				REV:	V0
上海有乐电气有限公司 Shanghai YouLe Electric CO., LTD				TITLE	TB1-15XX-B-1Y-00A
					TB1-15XX-B-成品