

REVISION RECORD			
REV.	CONTENT	MOD.	DATE
△	初版发行		

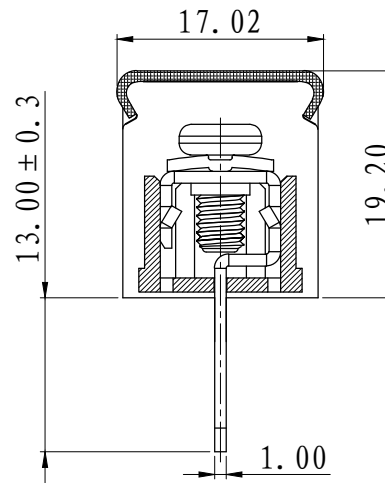
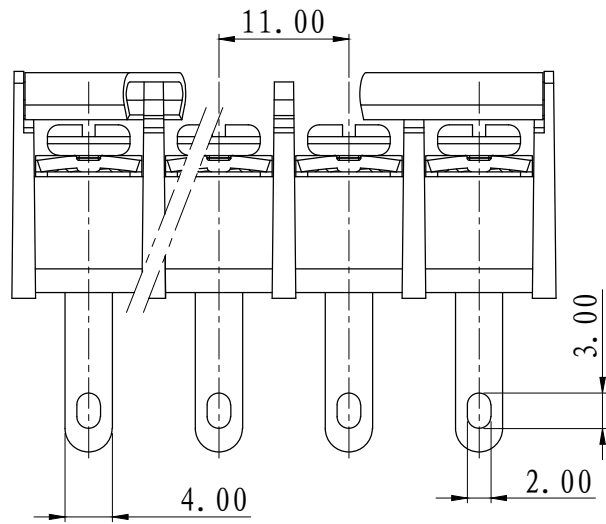
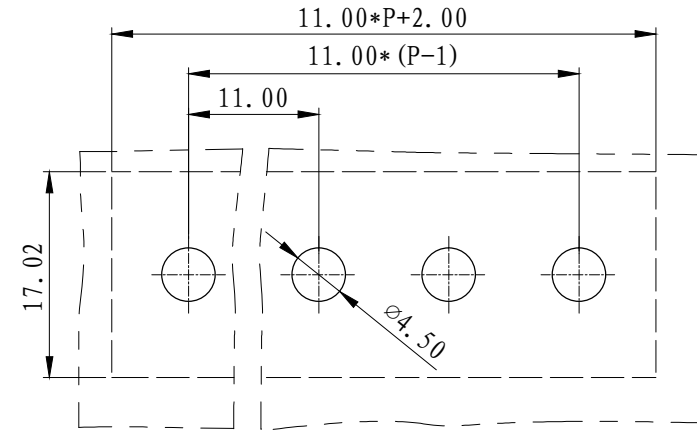
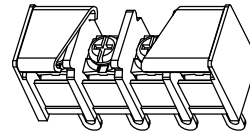
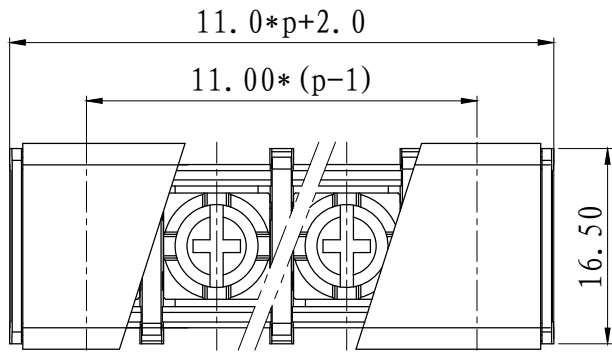

NOTES:

1. Voltage Rating: 300V, Current Rating: 20A
2. PITCH: 11.0mm
3. Insulation Withstands Voltage: AC2500V/min
4. Using Temperature Range: -40°C - +130°C
5. Suitable Electric Wire: AWG 22-12
6. Screw Torque Value: 1.2 N.m

技术要求:

1. 额定电压: 300V, 额定电流: 20A
2. 间距: 11.0mm
3. 耐电压值: AC 2500V/min
4. 使用条件: -40°C - +130°C
5. 适用线规: AWG 22-12
6. 螺丝扭力: 1.2N.m

	pitch dimension			Nominal dimension					— /
	over 0	over 6	over 10	over 0	over 30	over 60	over 100	over 150	
variable range	to 6	to 10	to 24	to 30	to 60	to 100	to 150		□ ○
Tolerance	±0.1	±0.15	±0.25	±0.2	±0.3	±0.5	±0.7	±1.0	0.05/10

4	LW2-11.0盖子	5012C70XXAV	1	PC	透明
3	LW1Q-11.0焊脚	5008B0003AV	P	黄铜	镀雾锡
2	M4*8-9*9螺丝	SQFFA408063V	P	碳钢	三价铬钝化彩锌
1	LW2-11.0-本体	5012A0YXXAV	1	PBT	
NO.	NAME OF PART	NO. OF PART	Q' TY	MATERIAL	NOTES
DES.	陈明珠	DATE 24/04/19	UNITS	MM	THIRD ANGLE PROJECTION SHEET
CHK.	张华丰	DATE 24/04/19	SIZE	A4	1 of 1
APP.		DATE	SCALE	1:1	DWG NO. SP-2-5012003 REV: V0
上海有乐电气有限公司 Shanghai YouLe Electric CO.,LTD				TITLE	LW2Q-11.0-XXP-1Y-00A LW2Q-11.0-成品